

# PROFIED ALUMMINIUM BOX 20°

## COFFRE EN ALUMINIUM PROFILÉ 20°

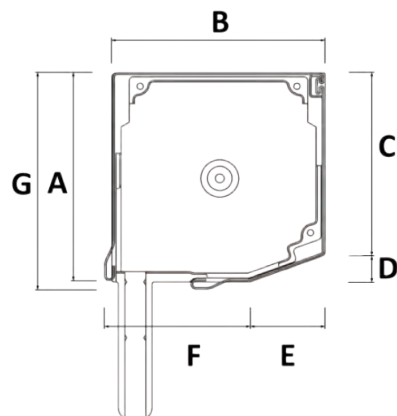

### BOX PARTS DIMENSIONS

#### DIMENSIONS DES PARTIES DU CAISSON

DIAMETER (Ø) DIAMÈTRE (Ø)	A	B	C	D	E	F	G	Thickness Épaisseur
138	14,04	14,04	11,48	2,16	5,88	8,16	14,04	0,7
165	16,9	16,9	14,22	2,28	6,21	10,69	16,9	0,8/1
180	18,38	18,48	15,33	2,65	7,21	11,27	18,38	0,8/1
205	20,93	21,07	17,46	3,07	8,38	12,69	20,93	1

### HEIGHT OF ROLLER SHUTTERS IN BOXES ENROULEMENTS EN CM.

SLATS LAMES	39 mm			40C mm			40+ mm			43 mm			43+ mm			45C mm			45 mm			45Pmm		
AXIS AXES	40	60	ZF54	40	60	ZF54	40	60	ZF54	40	60	ZF54	40	60	ZF54	40	60	ZF54	40	60	ZF54	40	60	ZF54
Alu. 20° 137	152	148	135	160	160	144	168	160	144	133	137	115	150	159	137	148	148	140	112	130	110	81	81	80
Alu. 20° 165	245	234	220	272	260	260	268	248	248	215	206	215	241	232	241	238	229	240	216	211	180	126	126	125
Alu. 20° 180	292	284	270	344	328	360	332	316	324	270	258	285	305	297	314	310	292	310	274	261	265	171	166	145
Alu. 20° 205	393	370	375	440	432	432	444	420	420	365	356	365	404	396	404	391	391	400	373	360	325	225	243	220

SLATS LAMES	50 mm			50+ mm			51+ mm		55C mm		
AXIS AXES	40	60	ZF54	40	60	ZF54	60	ZF54	60	70	ZF54
Alu. 20° 137	95	90	95	100	95	95	90	95	99	-	-
Alu. 20° 165	165	155	180	180	165	180	175	180	165	-	-
Alu. 20° 180	230	220	225	235	215	225	225	230	220	209	-
Alu. 20° 205	300	300	300	325	315	300	315	310	286	275	-

- These quantities are indicative. Expressed in centimeters.
- Ces quantités sont indicatives. Exprimées en centimètres.

### TECHNICAL DATA CARACTÉRISTIQUES TECHNIQUES

POLYAMIDE	NORM.	VALUE
Thickness Épaisseur peinture	EN 13523-1	22±2μ
Gloss (60%) Brillance (60%)	EN 13523-2	Matt-Matt 10-20% Middle gloss-Brillance moyenne 30-60% Gloss-Brillance >80%
Control color Contrôle de la couleur	EN 13523-3	-
Pencil Hardness Dureté au crayon	EN 13523-4	H - 2H
T Bending test Tes de pliage en T	EN 13523-7	0T - 1T
Rubbing Test. Mek test Test de frottement.	EN 13523-11	100 - 120 D.F.
Acetic salt spray Sel acétique	EN ISO 9227 AASS:2012	1000 hours/heures

SIDE ONE FACE 1	POLYURETHANE POLYAMIDE POLIÉSTER
SIDE TWO FACE 2	EPOXY POLIÉSTER

ALUMINIUM PROPERTIES PROPRIÉTÉS DE L'ALUMINIUM	
ALLOY ALLIAGE	3005
THICKNESS ÉPAISSEUR	0,7 - 1,0 MM
HARDNESS DURETÉ	H44 - H22

### MANUFACTURING FEATURES CARACTÉRISTIQUES DE CONSTRUCTION

	20°	
Manufacturing length Fabrication longue	6	ml
Packing Emballage		
125 - 205	30	ml
230 - 250	18	ml
300 - 400	12	ml